

TC...EB

TC...EB

TC...EB

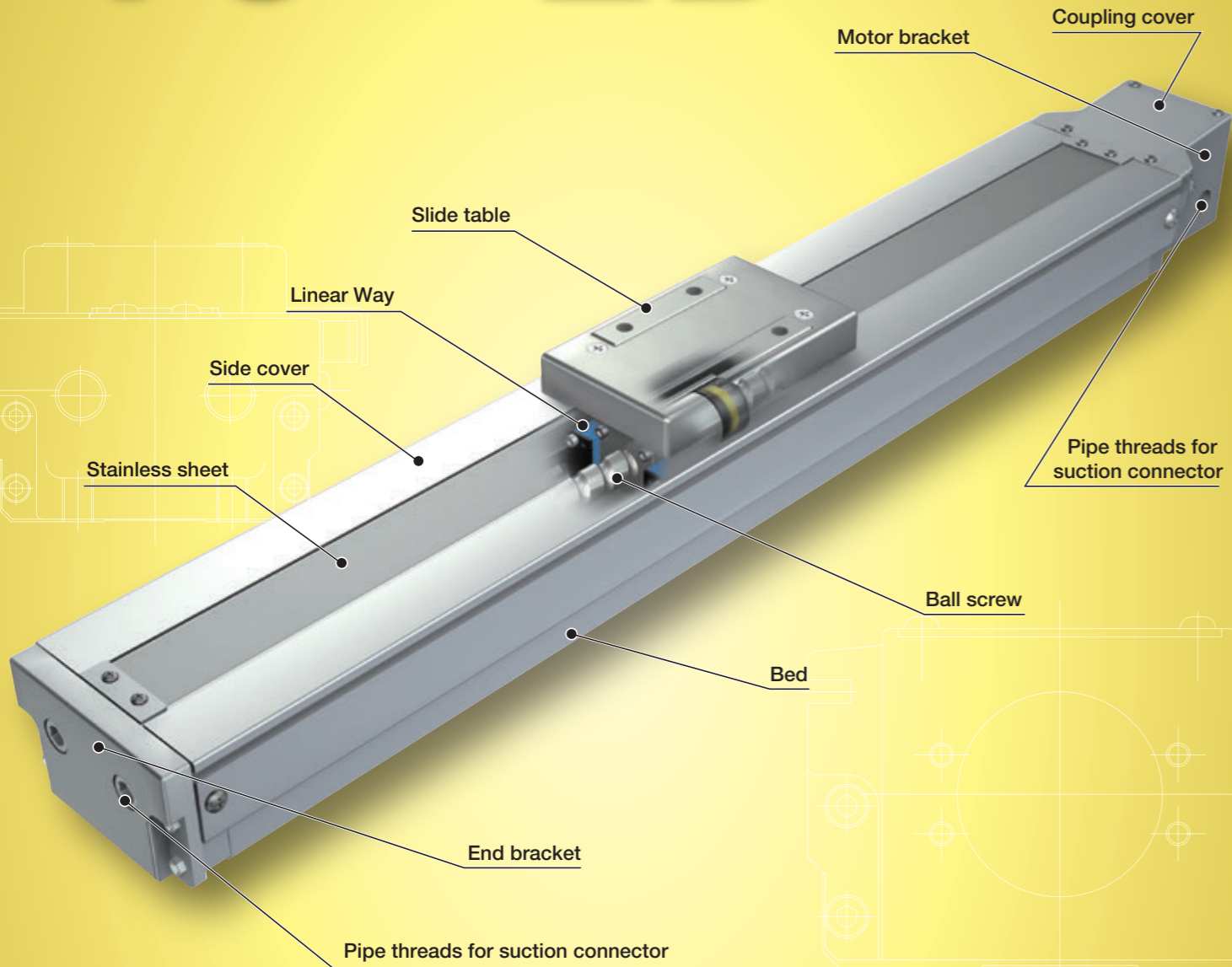
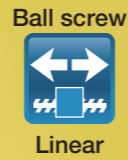

Points

● Light weight, low profile and compact clean table

1 Positioning table of a structure with enhanced sealing property inside the table, based on light weight, low profile and compact Precision Positioning Table TE. Thanks to optimal design of linear motion rolling guide and ball screws, low cross sectional height as low as 50mm for TC50EB, 54mm for TC60EB and 67mm for TC86EB is realized. Since the sensor is designed to be directly mounted into the mounting groove, it contributes to space saving.

● High corrosion resistance

3 Anodized high-tension aluminum alloy and stainless steel (stainless sheet) are used in main components to ensure excellent corrosion resistance.

● Compatible with cleanliness class 3 [Page II-175](#)

2 Press the stainless sheet against the side cover using the resin roller within the slide table, securely absorb it with a strong magnet sheet and seal the drive parts and slide table guiding parts. Dust-generation in proximity is prevented by sucking air from an enclosed space and class 3 cleanliness rating based on IKO measurement method is realized. Low dust-generation grease CGL for clean environment is contained in slide table guiding parts and ball screws to suppress dust-generation.

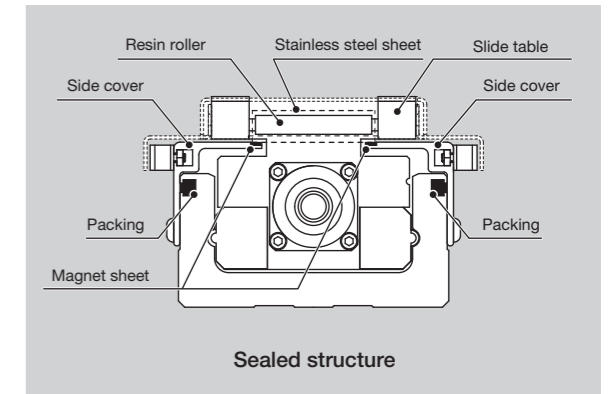

Variation

Shape	Model	Bed width (mm)		
		50	60	86
	TC...EB	☆	☆	☆

Major product specifications

Driving method	Precision ball screw
Linear motion rolling guide	Linear Way (ball type)
Built-in lubrication part	Lubrication part "C-Lube" is built-in
Material of table and bed	High-strength aluminum alloy
Sensor	Select by identification number

Accuracy

unit: mm

Positioning repeatability	±0.002
Positioning accuracy	0.035~0.065
Lost motion	-
Parallelism in table motion A	-
Parallelism in table motion B	0.008~0.016
Attitude accuracy	-
Straightness	-
Backlash	0.005

About measurement of cleanliness

Cleanliness refers to classified air cleanliness levels based on size (particle diameter) and quantity of suspended particulates per unit volume. IKO measures cleanliness by following the procedures.

Measuring condition

Item	Content
Measuring equipment	Particle counter
Air flow velocity of measurement part	2.5m/s
Measured air quantity	28.3L (1cf)
Measurement time	48h (10min/measurement, 1measurement/h)

Appearance of test device

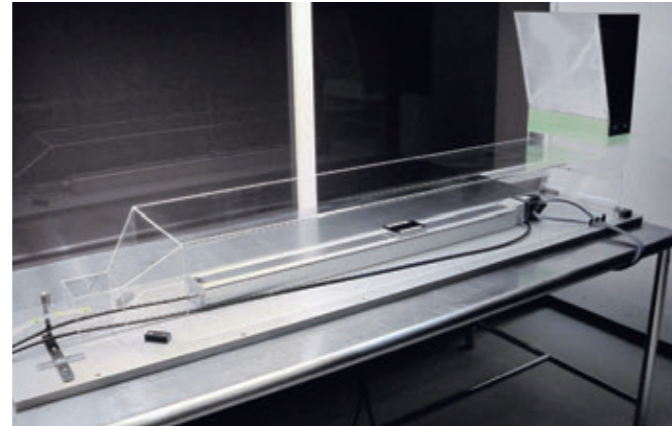

Outline of test device

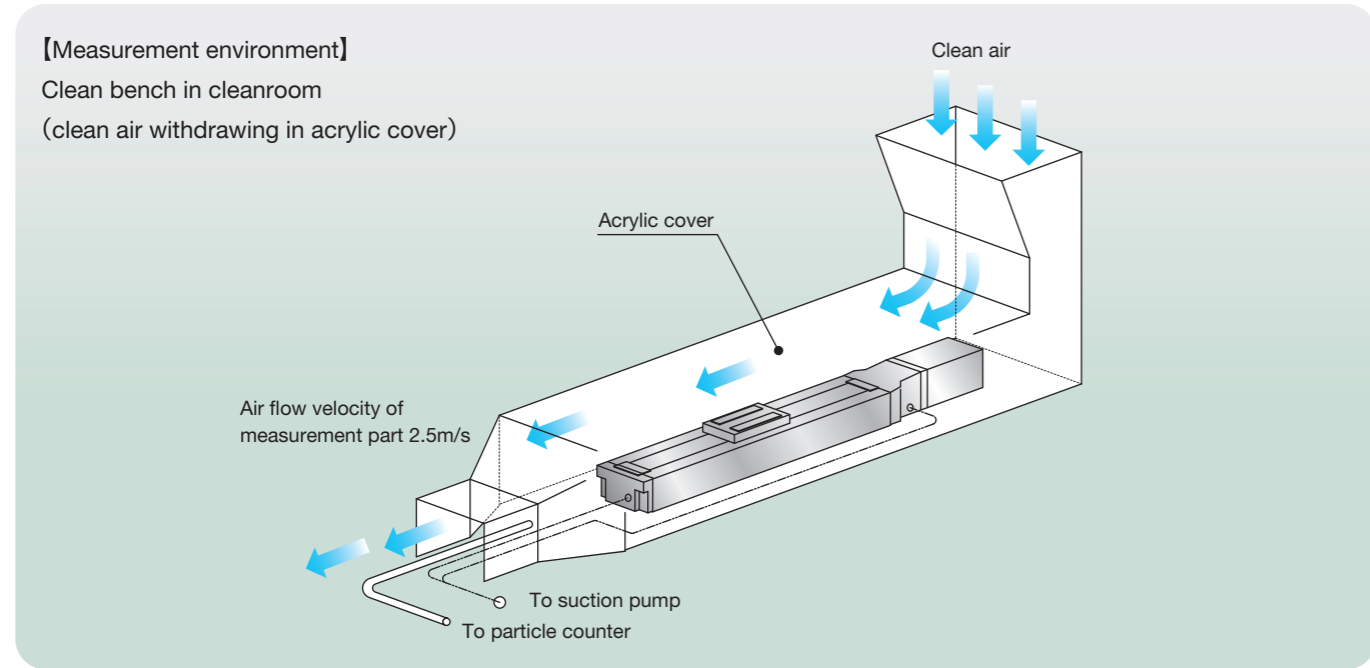

Upper concentration limit of each cleanliness class (JIS B 9920 : 2002, ISO 14644-1: 1999) unit: number of particles/m³

Cleanliness	Particle diameter			
	0.1μm or larger	0.2μm or larger	0.3μm or larger	0.4μm or larger
Class 1	10	2	—	—
Class 2	100	24	10	4
Class 3 (Federal Standard 209D Class 1)	1 000	237	102	35
Class 4 (Federal Standard 209D Class 10)	10 000	2 370	1 020	352
Class 5 (Federal Standard 209D Class 100)	100 000	23 700	10 200	3 520
Class 6 (Federal Standard 209D Class 1000)	1 000 000	237 000	102 000	35 200

Actual measurement data of cleanliness

Example of measurement data [Upper concentration limit chart for each cleanliness class]

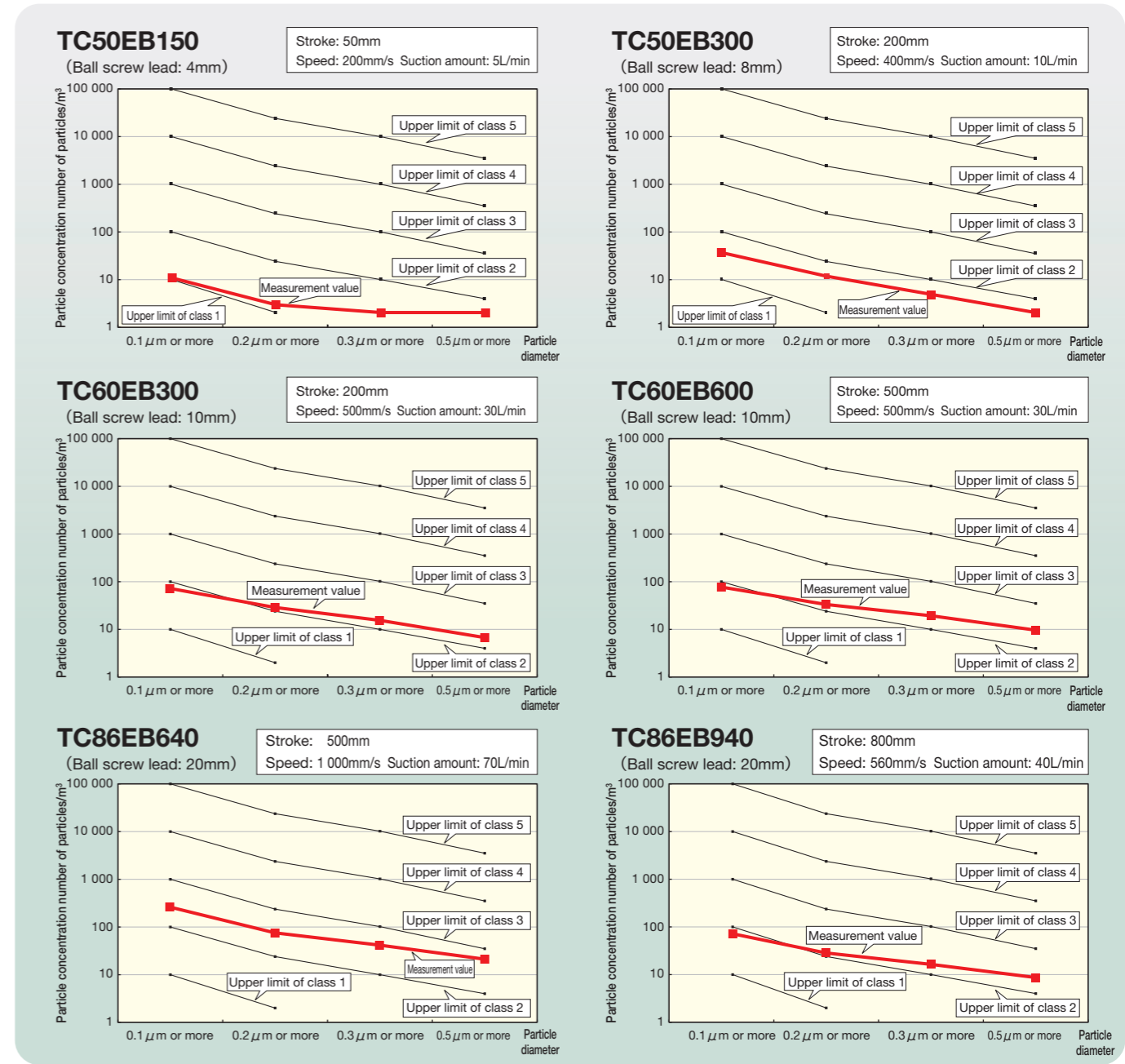

Measurement result of cleanliness

Model and size	Bed length	Ball screw lead mm	Stroke length mm	Speed mm/s	Suction amount L/min	Cleanliness class (JIS B 9920:2002, ISO 14644-1: 1999)
TC50EB	150	4	50	200	5	Class 2
	200	4	100	200	10	Class 2
	300	8	200	400	10	Class 2
TC60EB	150	5	50	250	30	Class 3
	300	10	200	500	30	Class 3
	600	10	500	500	30	Class 3
TC86EB	340	10	200	500	30	Class 3
	640	10	500	500	40	Class 3
	640	20	500	1 000	70	Class 3
	940	20	800	560	40	Class 3

Remark: Cleanliness varies depending on operating environment and operating conditions.

1N=0.102kgf=0.2248lbs.
1mm=0.03937inch

Identification Number

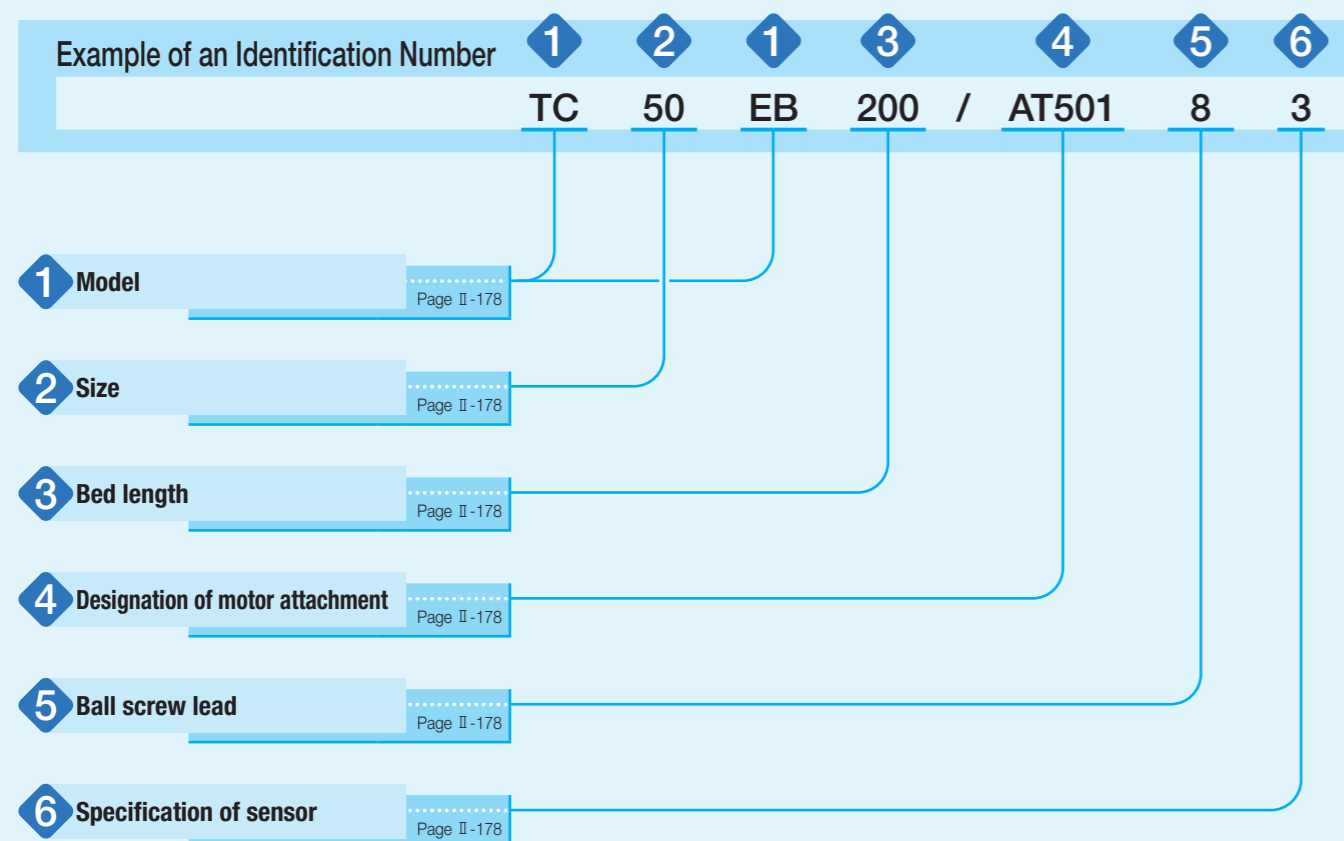

Identification Number and Specification

- 1 Model TC...EB: Cleanroom Precision Positioning Table TC
- 2 Size Size indicates bed width. Select a size from the list of Table 1.
- 3 Bed length Select a bed length from the list of Table 1.

Table 1 Sizes, bed widths, and bed lengths

Model and size	Bed width	Bed length (stroke length)						
		150(50)	200(100)	250(150)	300(200)	500(400)	600(500)	940(800)
TC50EB	50	150(50)	200(100)	250(150)	300(200)	—	—	—
TC60EB	60	150(50)	200(100)	300(200)	400(300)	500(400)	600(500)	—
TC86EB	86	340(200)	440(300)	540(400)	640(500)	740(600)	840(700)	940(800)

unit: mm

- 4 Designation of motor attachment
 - AT500: Without motor attachment
 - To specify the motor attachment, select it from the list of Table 2.
 - Motor should be prepared by customer.
 - Please specify motor attachment applicable to motor for use.
 - If motor attachment is specified, a coupling shown in Table 3 is mounted on the main body before shipment. However, the final position adjustment should be made by customer since it is only temporarily fixed.
 - For a product without motor attachment (AT500), no coupling is attached.
- 5 Ball screw lead
 - 4: Lead 4mm (applied to TC50EB)
 - 5: Lead 5mm (applied to TC60EB)
 - 8: Lead 8mm (applied to TC50EB)
 - 10: Lead 10mm (applied to TC60EB and TC86EB)
 - 20: Lead 20mm (applied to TC86EB)
- 6 Specification of sensor
 - 0: Without sensor
 - 2: Two units of sensor mounted (limit)
 - 3: Three units of sensor mounted (limit, pre-origin)
 - 4: Four units of sensor mounted (limit, pre-origin, origin)
 - 5: Two sensors attached (limit)
 - 6: Three sensors attached (limit and pre-origin)
 - 7: Four sensors attached (limit, pre-origin, origin)

If sensor mounting (symbol 2, 3, or 4) is specified, the sensor is mounted into the mounting groove on the side cover, and two detecting plates are attached onto the slide table.

If sensor attachment (symbol 5, 6, or 7) is specified, mounting screws and nuts for sensor are provided in addition to the specified number of sensors, and two detecting plates are attached onto the slide table.

Table 2 Application of motor attachment

Models of motor to be used					Flange size	Motor attachment		
Type	Manufacturer	Series	Model	Rated output W		TC50EB	TC60EB	TC86EB
AC servo motor	YASKAWA ELECTRIC CORPORATION	Σ-7	SGM7J-A5A	50	□40	AT501	AT502	—
			SGM7A-A5A			AT501	AT502	—
			SGM7J-01A	100		—	AT502	—
			SGM7A-01A			—	AT502	—
			SGM7J-02A	200		—	—	AT503
			SGM7A-02A			—	—	AT503
	Mitsubishi Electric Corporation	J4/J5	HG-MR053	50	□40	AT501	AT502	—
			HG-KR053/HK-KT053W			AT501	AT502	—
			HG-MR13	100		—	AT502	—
			HG-KR13/HK-KT13W			—	AT502	—
			HG-MR23	200		—	—	AT503
			HG-KR23/HK-KT23W			—	—	AT503
	Panasonic Corporation	MINAS A6	MSMF5A	50	□38	AT504	AT505	—
			MSMF01	100		—	AT505	—
			MSMF02	200		—	—	AT506
	Hitachi Industrial Equipment Systems Co., Ltd	AD	ADMA-R5L	50	□40	AT501	AT502	—
ADMA-01L			100	—		AT502	—	
ADMA-02L			200	—		—	AT503	
Stepper motor	ORIENTAL MOTOR Co., Ltd.	α step	ARM46	—	□42	AT507	—	—
			ARM66	—		—	AT508	
			ARM69	—		—	AT508	
			CRK54	—		AT509	—	—
			CRK56 (1)	—		—	AT510	AT511

Note (1) Applicable to the outer diameter φ8 of motor output shaft.
Remark: For detailed motor specifications, please see respective motor manufacturer's catalog.

Table 3 Coupling models

Motor attachment	Coupling models	Manufacturer	Coupling inertia J_c $\times 10^{-5} \text{kg} \cdot \text{m}^2$
AT501	XGS-19C-5× 8	Nabeya Bi-tech Kaisha	0.062
AT502	XGS-19C-5× 8	Nabeya Bi-tech Kaisha	0.062
AT503	XGS-30C-8×14	Nabeya Bi-tech Kaisha	0.55
AT504	XGS-19C-5× 8	Nabeya Bi-tech Kaisha	0.062
AT505	XGS-19C-5× 8	Nabeya Bi-tech Kaisha	0.062
AT506	XGS-30C-8×11	Nabeya Bi-tech Kaisha	0.55
AT507	XGS-19C-5× 6	Nabeya Bi-tech Kaisha	0.062
AT508	XGS-30C-8×10	Nabeya Bi-tech Kaisha	0.55
AT509	XGS-19C-5× 5	Nabeya Bi-tech Kaisha	0.062
AT510	XGS-19C-5× 8	Nabeya Bi-tech Kaisha	0.062
AT511	XGS-30C-8× 8	Nabeya Bi-tech Kaisha	0.55

Remark: For detailed coupling specifications, please see respective manufacturer's catalog.

Table 4 Accuracy

unit: mm

Model and size	Bed length	Positioning repeatability	Positioning accuracy	Parallelism in table motion B	Backlash
TC50EB	150	±0.002	0.035	0.008	0.005
	200				
	250		0.040		
	300				
TC60EB	150	±0.002	0.035	0.008	0.005
	200		0.040		
	300				
	400		0.045		
	500				
TC86EB	340	±0.002	0.040	0.008	0.005
	440		0.045		
	540				
	640		0.050		
	740				
	840		0.055		
	940				
		0.016			

Table 5 Maximum carrying mass

Model and size	Ball screw lead mm	Carrying mass center of gravity mm	Maximum carrying mass kg								
			Length L	Horizontal direction				Vertical direction			
				0	100	200	300	0	100	200	300
TC50EB	4	Height H	0	12	12	7	5	11	6	3.7	2.5
			100	12	12	7	4.9	6	4.3	2.9	2.1
			200	12	11	6	4.7	3.5	2.8	2.3	1.8
	8		300	12	10	6	4.5	2.4	2.0	1.8	1.6
			0	12	10	5	3.9	7	5	2.9	2.0
			100	12	8	5	3.6	4.9	3.3	2.3	1.6
TC60EB	5	200	12	7	4.5	3.3	2.7	2.2	1.8	1.4	
		300	10	6	4.1	3.1	1.9	1.6	1.4	1.2	
		0	17	17	11	8	13	10	5	3.8	
	10	100	17	17	10	7	9	6	4.3	3.2	
		200	17	16	10	7	5	4.1	3.4	2.7	
		300	17	14	9	7	3.6	3.1	2.7	2.3	
TC86EB	10	0	17	15	8	5	8	7	4.3	2.9	
		100	17	11	7	5	7	4.9	3.3	2.5	
		200	17	9	6	4.8	4.0	3.2	2.6	2.1	
	20	300	13	8	5	4.4	2.8	2.4	2.0	1.8	
		0	36	36	26	18	18	18	13	9	
		100	36	36	22	16	18	15	10	8	
20	200	36	29	20	15	12	10	8	6		
	300	36	25	18	14	9	7	6	5		
	0	29	28	16	11	10	10	10	6		
	100	29	20	13	10	10	10	7	5		
	200	23	15	11	8	9	7	6	5		
300	17	12	9	7	6	5	4.9	4.3			

Remark 1. The maximum carrying mass is adjusted by the mass when the rating life of the linear motion rolling guide, ball screws, or bearings is 18,000 hours during continuous operation at a number of revolutions of the motor of 3000min⁻¹ and an acceleration/deceleration time of 0.2s. The mass calculated is based upon the basic static load rating of the linear motion rolling guide.
2. Please refer to the carrying mass center of gravity diagrams on page II-181 for details on length L and height H.
3. Please also check the maximum load mass on page III-19.

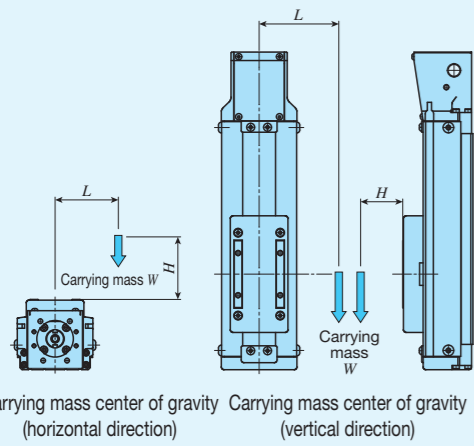

Table 6 Allowable moment

Model and size	Allowable moment N · m
TC50EB	5.0
TC60EB	6.0
TC86EB	10.0

Remark: Applied in all directions.

■ Allowable moment

Allowable moment refers to the maximum static moment that can be used without affecting functions or performance. Therefore, do not exceed the allowable moment value during operation.

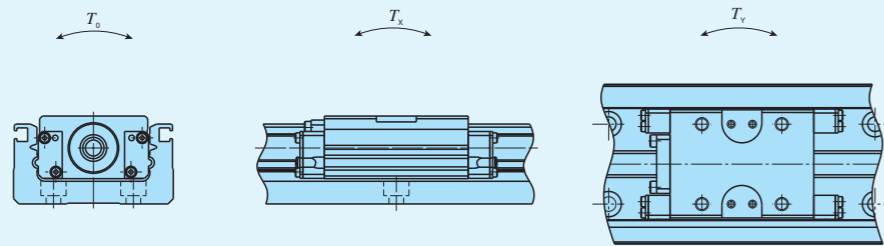

Table 7 Load rating of linear motion rolling guide

Model and size	Basic dynamic load rating C N	Basic static load rating C ₀ N	Static moment rating N·m		
			T ₀	T _x	T _y
TC50EB	8 490	12 500	211	99.5	99.5
TC60EB	12 400	17 100	354	151	151
TC86EB	26 800	35 900	1 110	472	472

Table 8 Maximum speed

Motor type	Model and size	Bed length mm	Maximum speed mm/s				
			Lead 4mm	Lead 5mm	Lead 8mm	Lead 10mm	Lead 20mm
AC servo motor	TC50EB	—	200	—	400	—	—
	TC60EB	—	—	250	—	500	—
	TC86EB	640 or less	—	—	—	500	1 000
		740	—	—	—	500	1 000
		840	—	—	—	400	800
940	—	—	—	330	660		
Stepper motor	TC50EB	—	120	—	240	—	—
	TC60EB	—	—	150	—	300	—
	TC86EB	840 or less	—	—	—	300	600
		940	—	—	—	300	600

Remark: To measure the practical maximum speed, it is required to consider operation patterns based on the motor to be used and load conditions.

Table 9.1 Specifications of ball screw 1

Model and size	Lead mm	Shaft dia. mm	Basic dynamic load rating C N	Basic static load rating C ₀ N
TC50EB	4	8	2 290	3 575
	8		1 450	2 155
TC60EB	5	10	2 730	4 410
	10		1 720	2 745
TC86EB	10	12	3 820	6 480
	20		2 300	3 920

Table 9.2 Specifications of ball screw 2

Model and size	Bed length	Shaft dia.	Overall length
TC50EB	150	8	192.5
	200		242.5
	250		292.5
	300		342.5
TC60EB	150	10	194
	200		244
	300		344
	400		444
	500		544
	600		644
TC86EB	340	12	395
	440		495
	540		595
	640		695
	740		795
	840		895
940	995		

unit: mm

Table 10 Moment of inertia of sectional area of bed

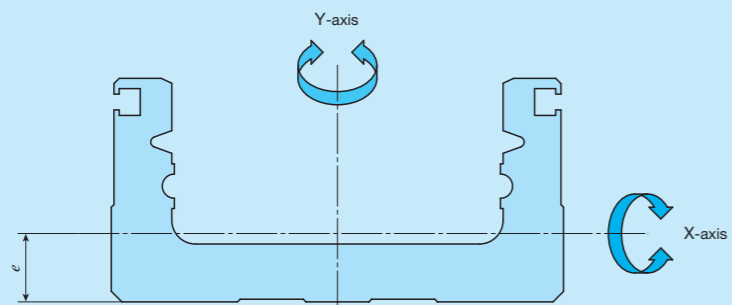

Model and size	Moment of inertia of sectional area mm ⁴		Center of gravity <i>e</i> mm
	<i>I_x</i>	<i>I_y</i>	
TC50EB	1.3×10 ⁴	1.2×10 ⁵	6.4
TC60EB	4.7×10 ⁴	3.2×10 ⁵	8.8
TC86EB	2.0×10 ⁵	1.3×10 ⁶	13.0

Table 11 Table inertia and starting torque

Model and size	Bed length mm	Table inertia <i>J_T</i> ×10 ⁻⁵ kg·m ²					Starting torque <i>T_s</i> N·m				
		Lead 4mm	Lead 5mm	Lead 8mm	Lead 10mm	Lead 20mm	Lead 4mm	Lead 5mm	Lead 8mm	Lead 10mm	Lead 20mm
TC50EB	150	0.062	—	0.092	—	—	0.03	—	0.03	—	—
	200	0.074	—	0.104	—						
	250	0.090	—	0.120	—						
	300	0.102	—	0.132	—						
TC60EB	150	—	0.14	—	0.21	—	—	0.03	—	0.04	—
	200	—	0.20	—	0.27	—					
	300	—	0.27	—	0.34	—					
	400	—	0.34	—	0.41	—					
	500	—	0.41	—	0.48	—					
600	—	0.49	—	0.55	—						
TC86EB	340	—	—	—	0.78	1.36	—	—	—	0.06	0.10
	440	—	—	—	0.93	1.51					
	540	—	—	—	1.08	1.66					
	640	—	—	—	1.23	1.81					
	740	—	—	—	1.38	1.96					
	840	—	—	—	1.53	2.11					
940	—	—	—	1.68	2.26						

Mounting

For the processing accuracy of the Precision Positioning Table mounting surface and the tightening torque of the fixing screws, see page III-36.

Sensor Specification

Table 12 Sensor timing chart

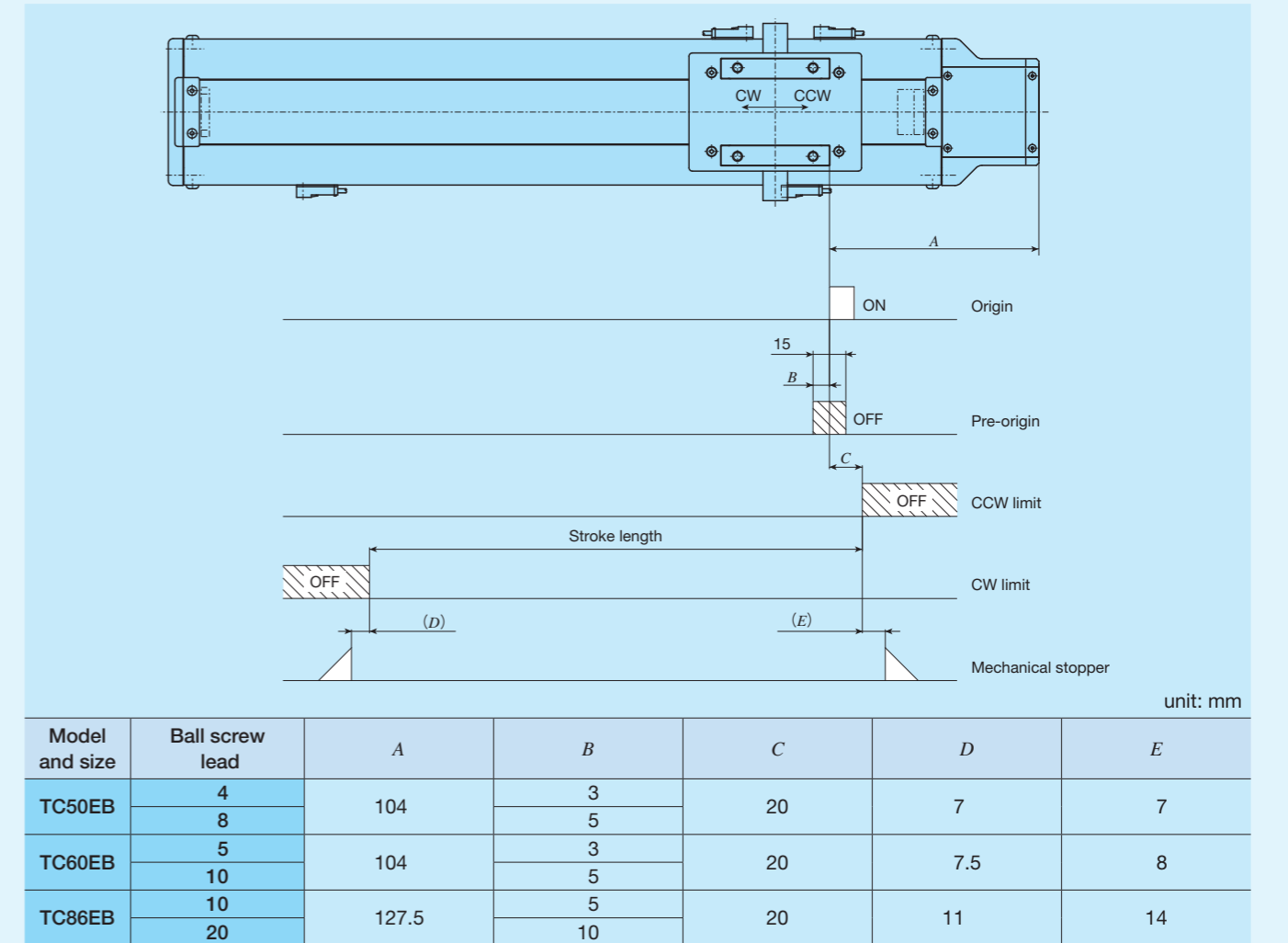

Remarks 1. Mounting a sensor is specified using the corresponding identification number.
2. For the specifications of respective sensors, please see the section of sensor specification in General Explanation.

Dimensions of Motor Attachment

TC50EB

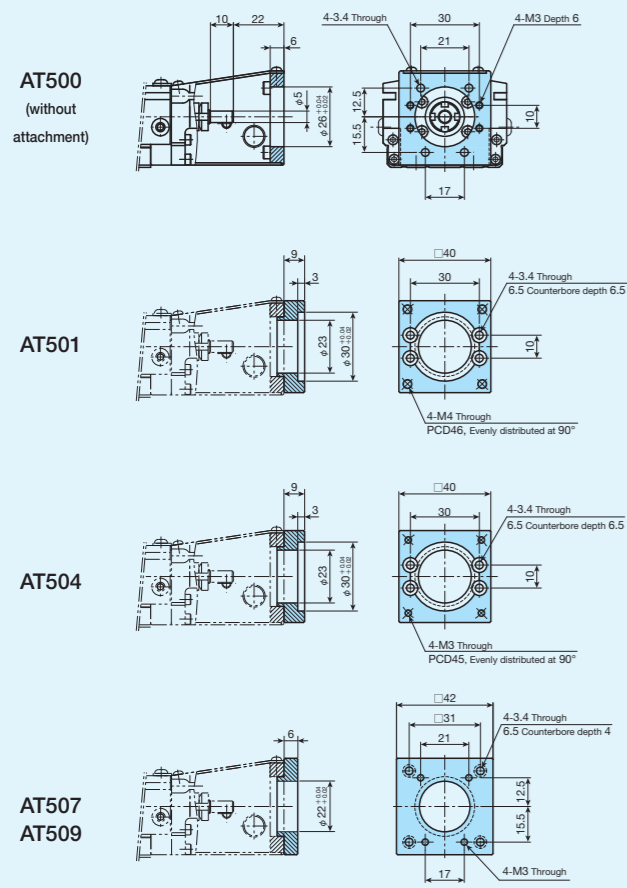

TC60EB

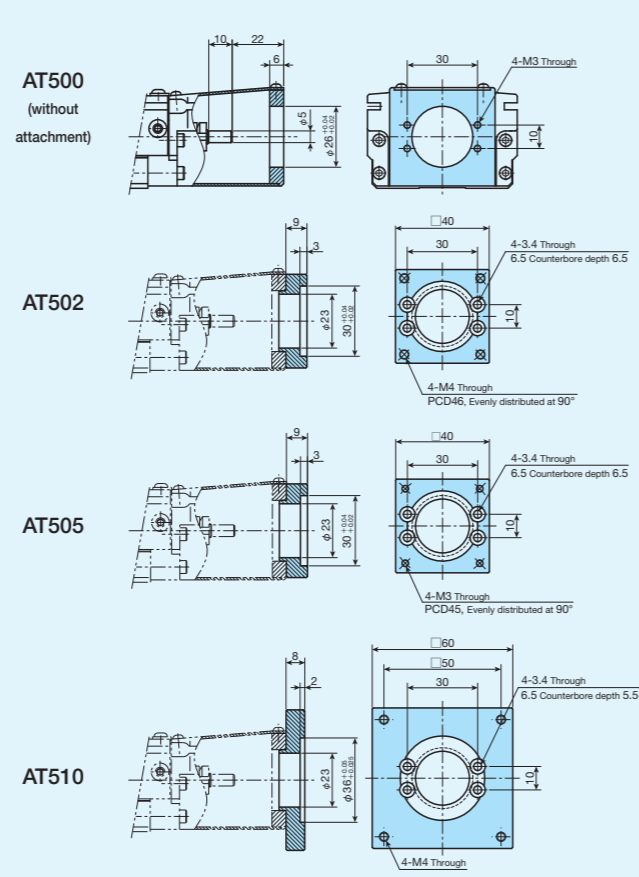

TC86EB

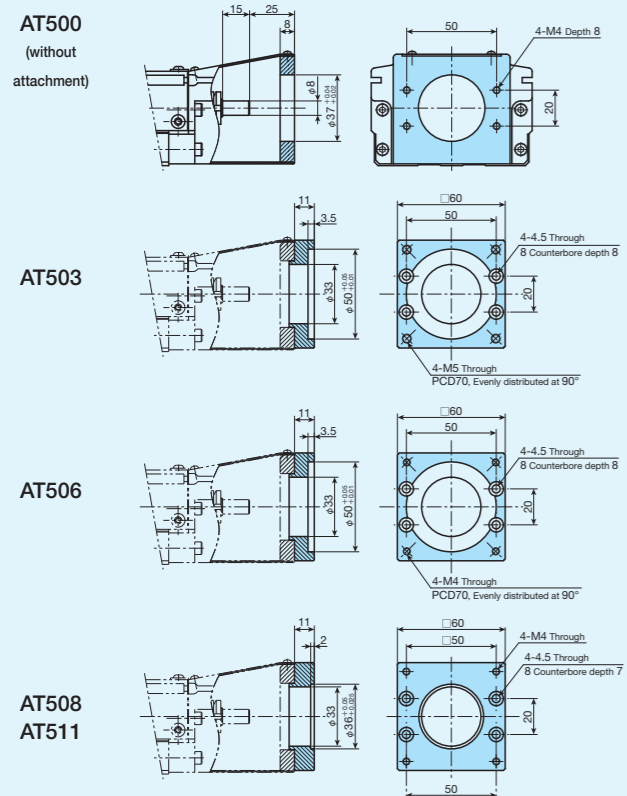

IKO Cleanroom Precision Positioning Table TC

TC50EB

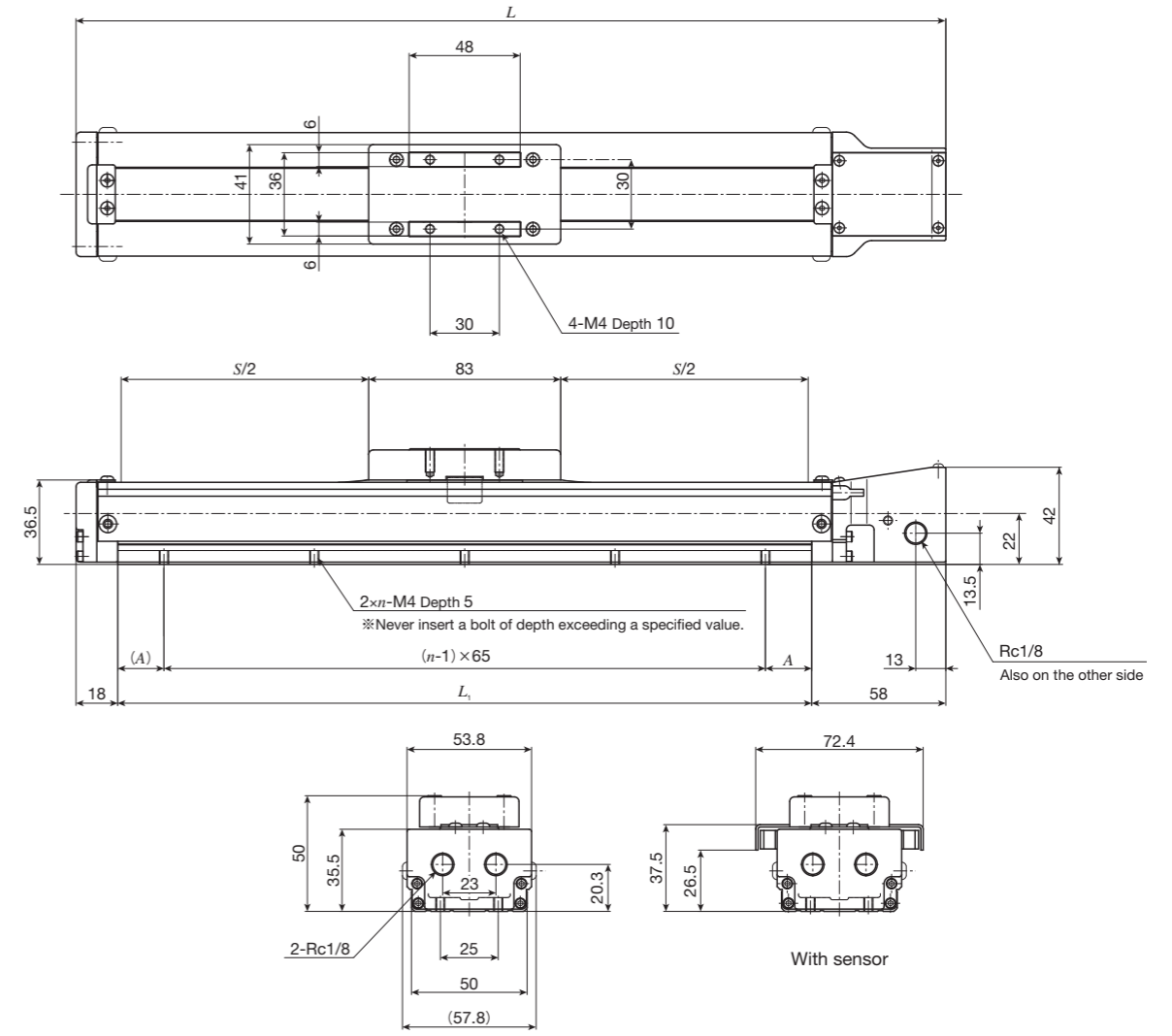

unit: mm

Bed length L_1	Overall length L	Stroke length S	Mounting holes of bed		Mass (Ref.) kg
			A	n	
150	226	50	10	3	0.9
200	276	100	35	3	1.0
250	326	150	27.5	4	1.1
300	376	200	20	5	1.2

IKO Cleanroom Precision Positioning Table TC

TC60EB

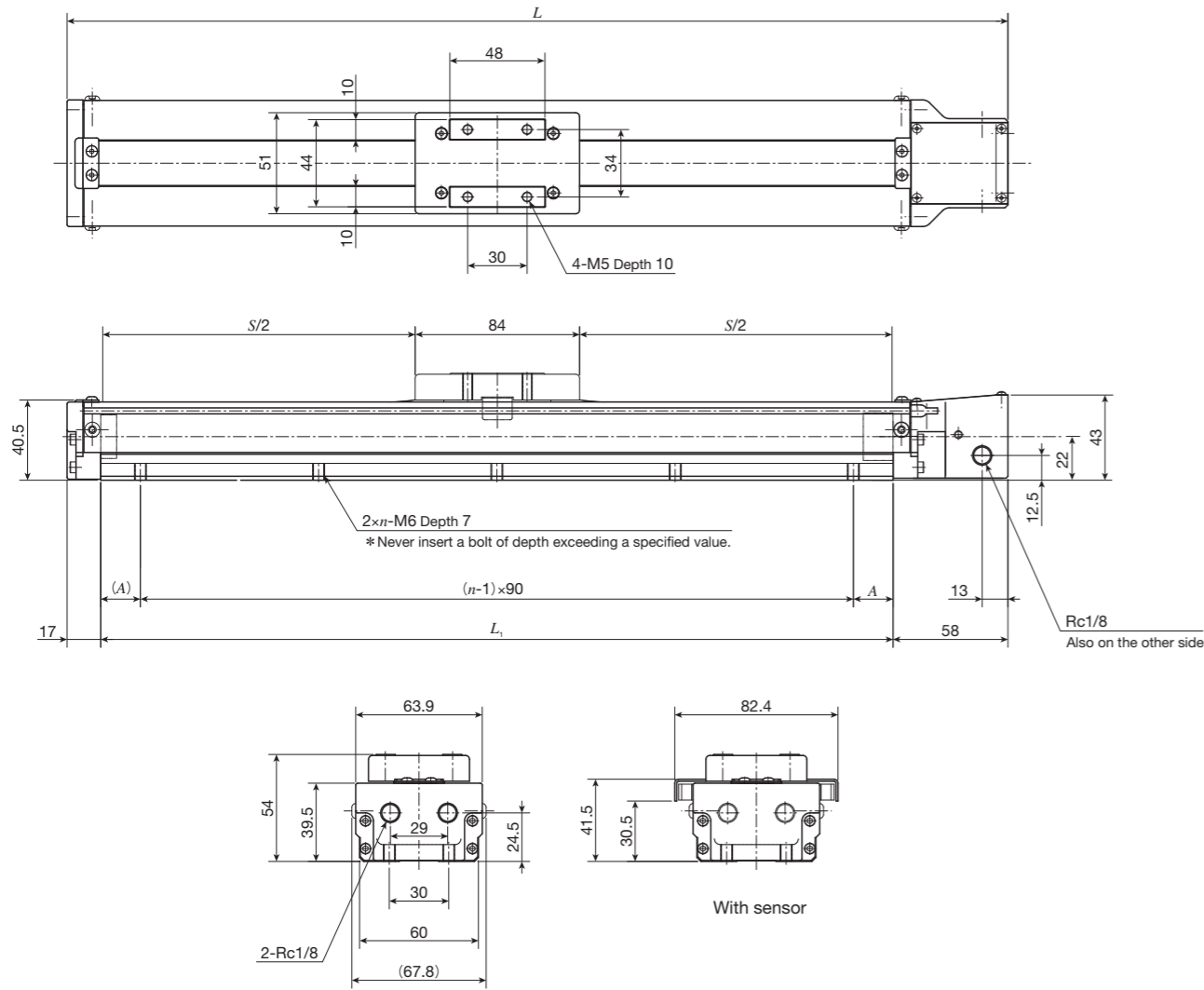

unit: mm

Bed length L_1	Overall length L	Stroke length S	Mounting holes of bed		Mass (Ref.) kg
			A	n	
150	225	50	30	2	1.1
200	275	100	10	3	1.3
300	375	200	15	4	1.7
400	475	300	20	5	2.0
500	575	400	25	6	2.4
600	675	500	30	7	2.7

Remark: Motor attachment for stepper motor is 8mm lower than the bottom of the bed.

TC86EB

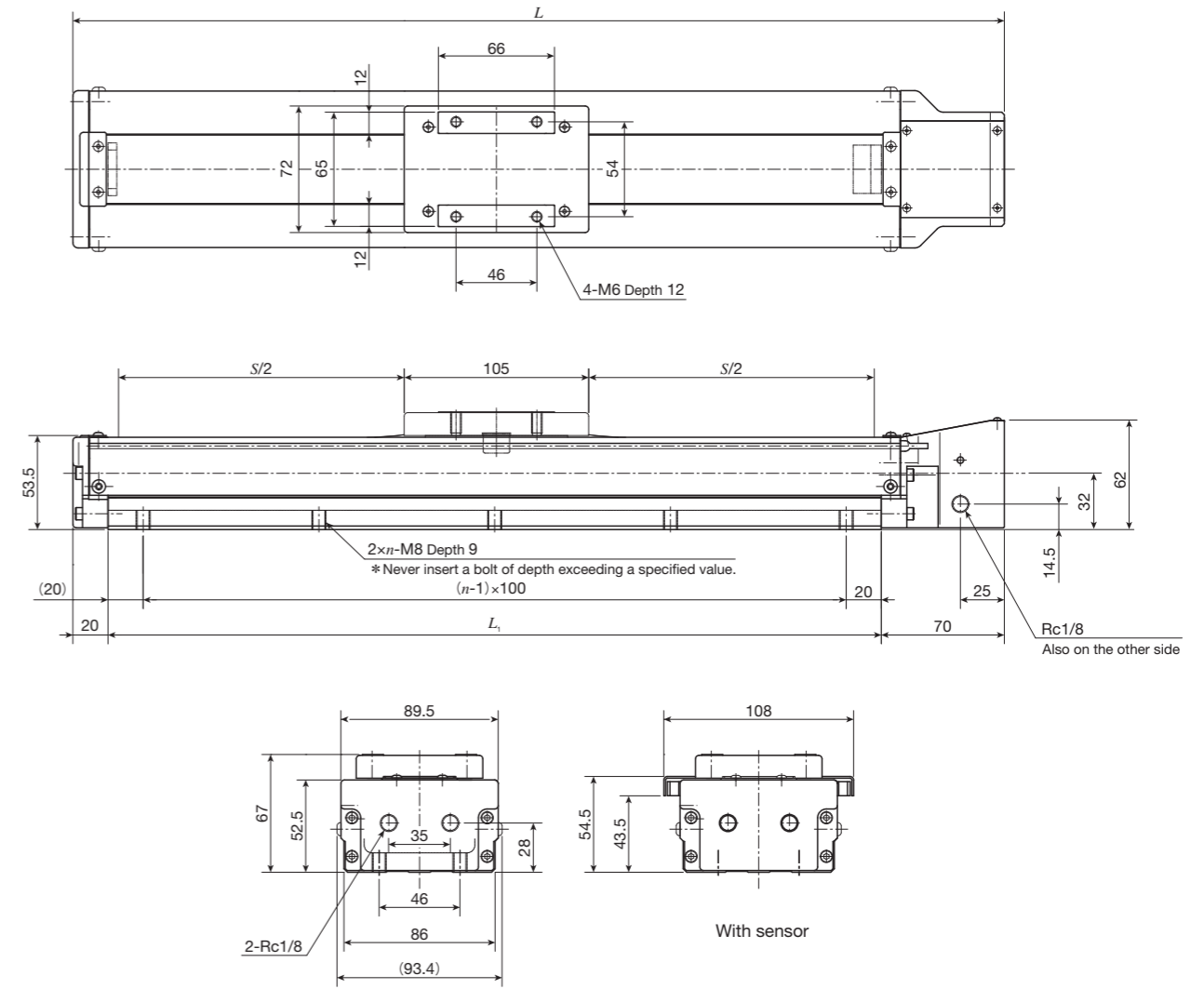

unit: mm

Bed length L_1	Overall length L	Stroke length S	Mounting holes of bed n	Mass (Ref.) kg
440	530	300	5	4.2
540	630	400	6	4.8
640	730	500	7	5.4
740	830	600	8	6.0
840	930	700	9	6.6
940	1 030	800	10	7.3